

RESISTANCE SOLDERING

- SOLDER TYPES
- HEAT SOURCES
- HEAT SINK EFFECT
- CLEAN SURFACES
- TYPE JOINTS
- RESISTANCE METHOD
 - SYSTEM COMPONENTS
 - OPERATION
 - TECHNIQUES

03.03.2013 14:



• TYPES SOLDER

- HARD
 - SILVER ALLOY 800°
- SOFT
 - LEAD/TIN 327°-450°
 - ROSIN CORE EUTECTIC 60/40 360°
 - ACID CORE
 - SILVER BEARING ROSIN CORE
FOR ELECTRONICS 60/38/2
- PASTE APPROX-200°

03.03.2013 15:

~ SOLDERING ~

3 - STEPS

1. CLEAN

- WEBSTER'S -

"FREE FROM DIRT OR
IMPURITIES"

CLEAN SURFACES

- BEAD OR SAND BLAST
- WIRE BRUSH - STEEL W-
- FILE
- SAND PAPER
- FLUX = NON CORR.

HEAT SOURCES

- GUN

- IRON

- 125 V. 25, 47, 100 WATTS

- TRANSFORMER - FIXED TEMP.

- TEMP. CONTROL 300°- 900°

- OPEN FLAME

*NOTE WHEN
SOLDER FLOWS*

- RESISTANCE SYS.

HEAT "SINKS"

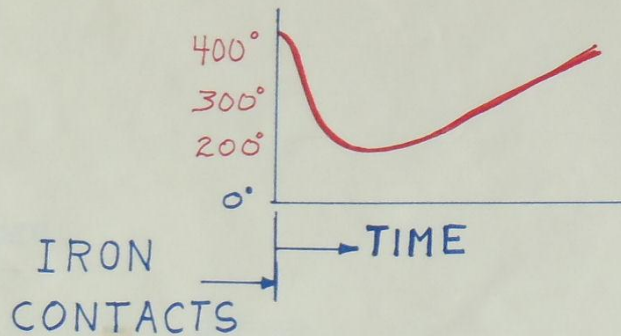
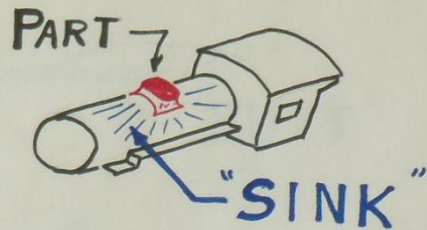
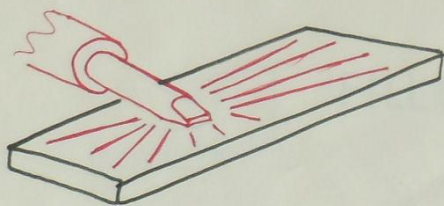

-
- THIN .001" - .030" - 1/32"
 - THICK .030" - .062" - 1/16"
 - HEAVY .062" - .125" - 1/8 +"

SOLDER JOINTS

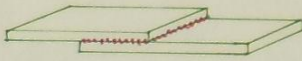

LAP



BUTT

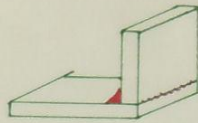

FILLET

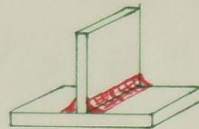

TEE

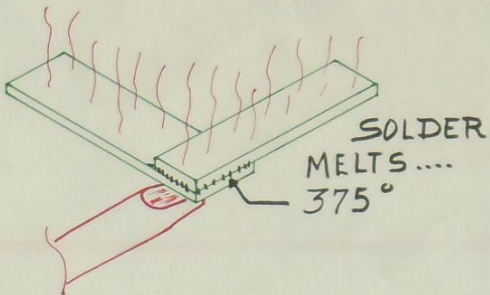

SOLDER
MELTS
375°

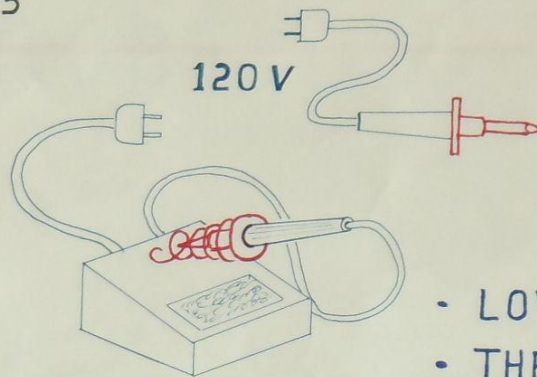

47 W
.3 A

- LOW VOLTS
- THERMOSTAT
350°-800° TEMP

RESISTANCE SYSTEM

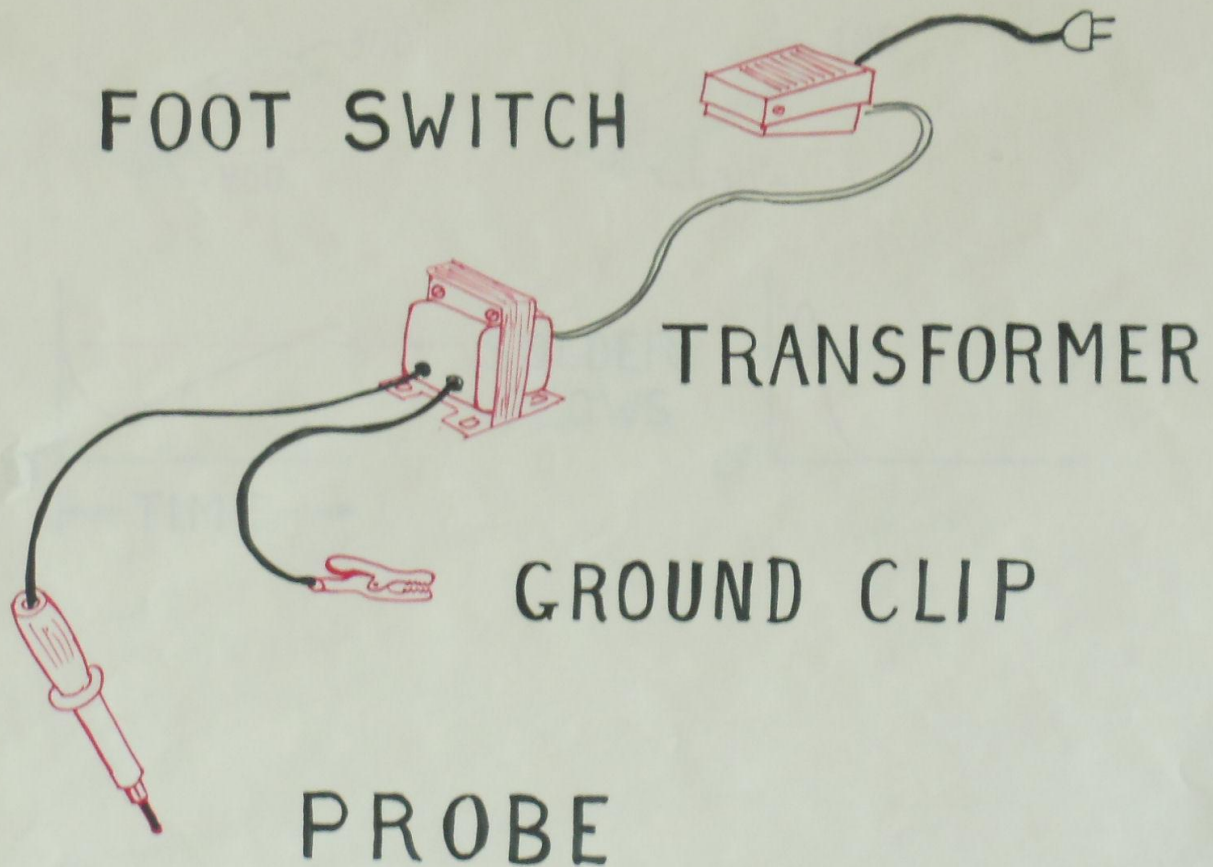

RESISTANCE OPERATION

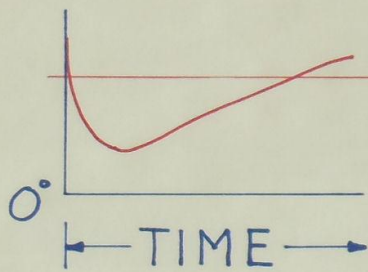
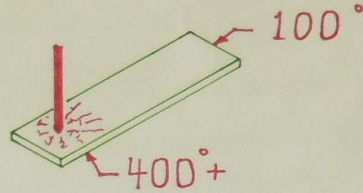
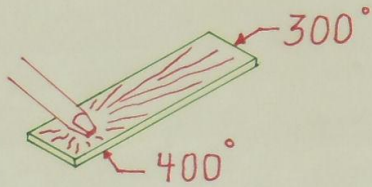

SOLDER
FLOWS

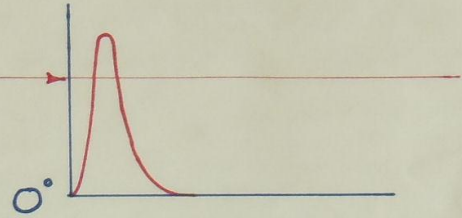

RESISTANCE OPER.

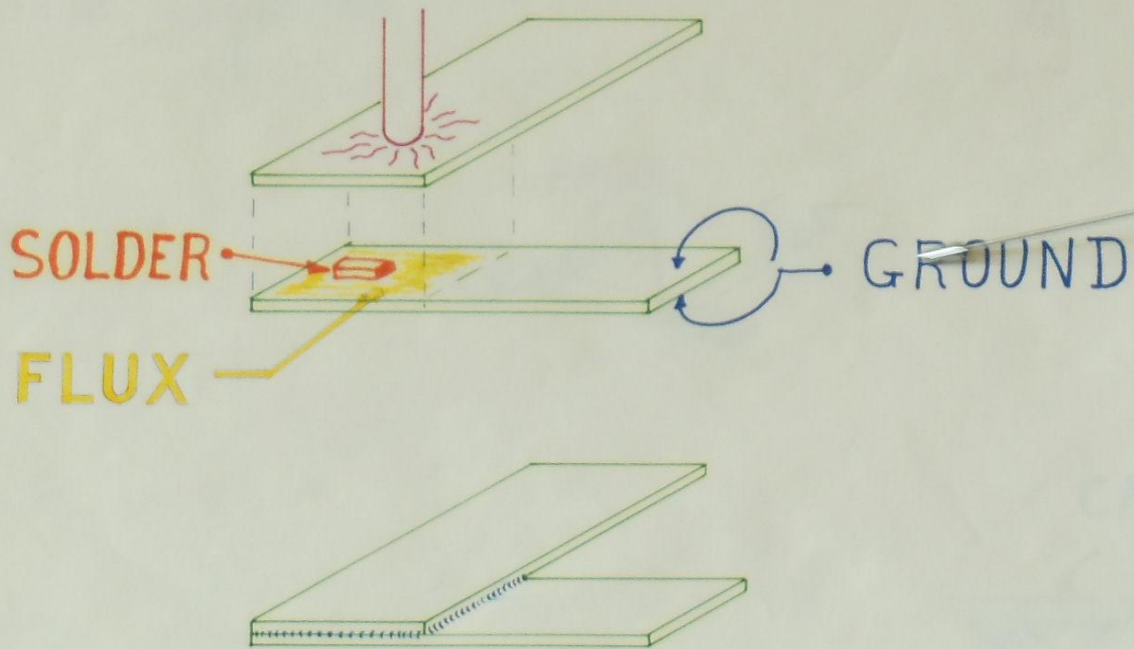

SOLDER JOINTS

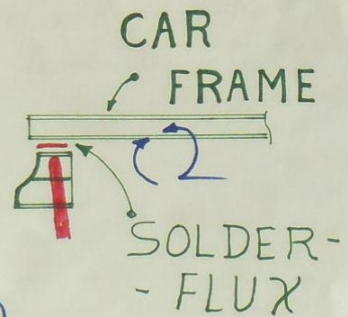
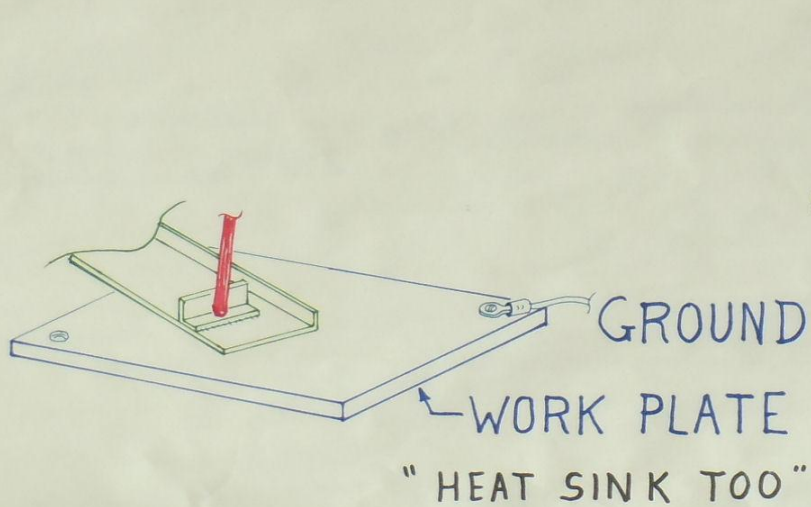
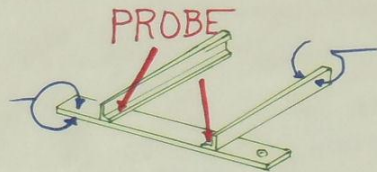
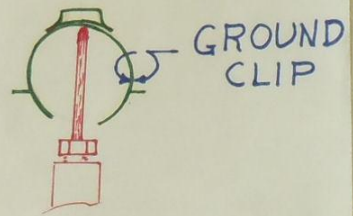
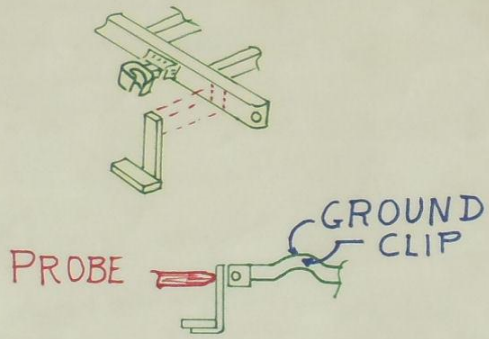

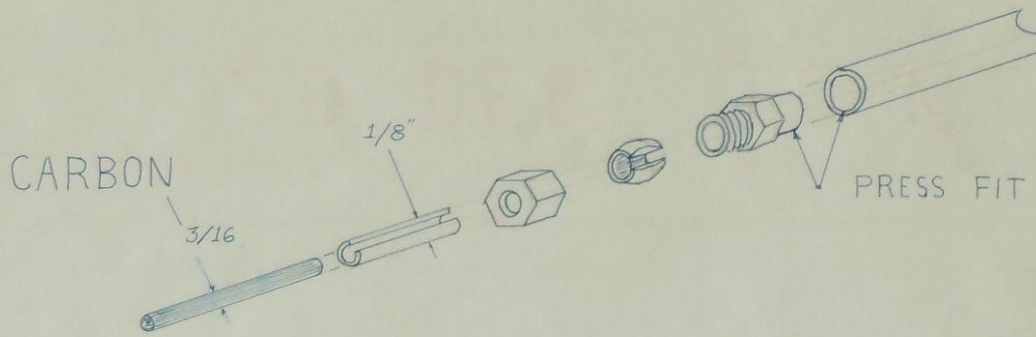

PROBES

